



Perma Tech, Inc.

"Your Single Source for ALL Your Loading Dock Needs"

PermaDOCK-MD



Mechanical Dock Leveler

OWNER'S MANUAL

**IMPORTANT TO CHECK SHIPPING CONTAINERS BEFORE RELEASING CARRIER.
NOTIFY CARRIER IMMEDIATELY UPON DISCOVERING ANY CONCEALED DAMAGE.**

WARNING : Do not install this product unless you have read and understand the warnings and installation instructions contained in the manual.



TF: (800) 362-7325 | P: (716) 854-0707
sales@permatechinc.com | www.permatechinc.com

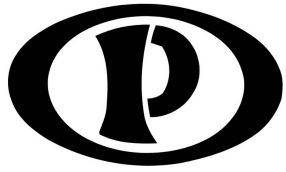

Perma Tech Inc.

TABLE OF CONTENTS

	Page
Safety Information	1
Installation Instructions	3
Shimming Details	4
Preliminary Operations	5
Operating Instructions	6
Mechanical Dock Leveler Diagram	7
Parts List for Mechanical Dock Levelers	8
Schematic Drawing & Parts List for Lifting Arm	9
Schematic Drawing & Parts List for Ratchet Hold Down	10
Schematic Drawing & Parts List for Lip Latch Assembly	11
Trouble Shooting	12
Maintenance & Lubrication	13
Warranty	14

Manufacture Date: _____

Model: _____

Serial #: _____

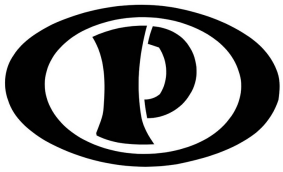

Perma Tech Inc.

SAFETY INFORMATION

WARNING

Failure to read and understand the entire contents of this manual may result in damage to the equipment, bodily injury and/or death. Never install, maintain or operate this equipment under the influence of drugs or alcohol.

INSTALLATION

- Personnel installing this equipment must be fully qualified and experienced in safe working procedures.
- All lifting and slinging devices must be in good working order and used in the correct manner.
- Concrete must be in good repair with no cracks in pit or around the dock leveler.
- Never go beneath the dock leveler unless the dock is barricaded in front of the dock leveler on the loading dock floor and driveway.
- Never go beneath the dock leveler unless the maintenance strut is in position.
- Do not alter the equipment.

MAINTENANCE

1. When replacing parts use only genuine **PermaDOCK Levelers** parts.
2. Never go beneath the dock leveler unless the dock is barricaded in front of the dock leveler on the loading dock floor and driveway.
3. Never go beneath the dock leveler unless the maintenance strut is in position.
4. Do not alter the equipment.

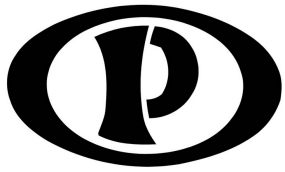

Perma Tech Inc.

SAFETY INFORMATION

OPERATION

NOTE: ALWAYS RESTRAIN THE TRUCK/TRAILER BEING LOADED/UNLOADED, I.E. BY USE OF WHEEL CHOCKS OR A TRUCK RESTRAINT DEVICE.

1. Keep clear of the equipment's operating path when positioning or storing the dock leveler.
2. Never lower the dock leveler with a lift truck.
3. Do not wear loose clothing or jewelry while operating this equipment.
4. Keep hands, limbs and loose hair clear of equipment during positioning or storing of the dock leveler.
5. Never go beneath the dock leveler unless the maintenance strut is in position.
6. Never continue to use the equipment if you believe it is unsafe because of bent structural members, broken welds, oil leaks, etc. Have the unit inspected by your nearest **Perma Tech Dock Leveler** representative.



INSTALLATION INSTRUCTIONS

Prior to installation, check pit for correct depth and square-ness of pit across corners. If pit is not correct in size and square-ness, make corrections before installation dock board.

IMPORTANT

Do not break bands on dock board until called for in Step 4, otherwise damage may occur which would not be covered by the warranty.

1. Place board in pit by means of crane or forklift, level back end of board with rear pit angle, weld angles as shown on Drawing.
2. Shim front end of board so as top deck of board is level with the rear angle.
3. Weld front base and shims to front curb angle.
4. With the board welded in the pit, remove bands; elevate deck by pulling release chain at rear of dock.
5. Block the board securely in the up position before working underneath the dock board.
6. Shim under back frame of the board and under the centre angle as shown on drawing. Weld shims to the angles.
7. Read operating instructions. Operate the board several times, pausing between operation to expel the air in system.

NOTE: WHILE THE DOCK BOARD IS FACTORY ADJUSTED, THEY MAY REQUIRE SLIGHT ADJUSTMENT ON SITE DUE TO THE MOVEMENT IN SHIPPING AND DURING THE INSTALLATION. **THIS IS NOT WARRANTY.**

We reserve the right to change specifications and/or design without notice or obligation.

Please state model number of dock board when ordering parts.



SHIMMING DETAILS

Dwg. #1

FRONT VIEW

18"

NOTE: Painted yellow guide line recommended

Dwg. #2

SIDE ELEVATION

Recommended Dock Height 48"

1/4" RUN OFF SLOPE

PIT DEPTH 20"

6.21

1/2" Min. Slope

Dwg. #3

A

LS LS LS LS

Leveling & Shims for Base

B

Dwg. #4

DETAIL: SHIMMING, WELDING AND BLOCKING

CAUTION: Block securely while working under the Dock

Approximately 3" weld at 4 places

19 1/2"

Shim & Weld at Lip Support

Weld Shims to Center Beam Support

Weld Shims to Base Frame

MODEL	"B" DIM	"A" DIM	MODEL	"B" DIM	"A" DIM
MD-66	74"	63"	MD-76	85"	63"
MD-68	74"	87"	MD-78	85"	87"
MD-610	74"	111"	MD-710	85"	111"
MD-612	74"	135"	MD-712	85"	135"

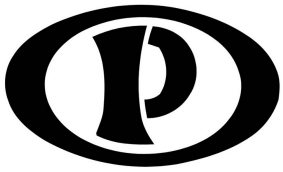

PRELIMINARY OPERATIONS

CAUTION

Never operate the dock leveler when someone is in front of the lip.

STEPS FOR FIRST TIME USAGE:

1. Pull and hold the release chain until the dock stops in its top position. Do not step on the deck. When the deck lifts to its highest position the lip will extend and lock into position automatically.
2. Walk to the top of the deck. The ramp will lower to its lowest position (below dock level) and hold its position.
3. Manually lift the lip 2". The lip locking mechanism will disengage. Carefully lower the lip to its vertical position.
4. Pull the release chain until the dock raises 6" above dock level. Stop the ramp by letting go of the release chain. Walk the ramp down to its stored position with lip behind the night lock.
5. Continue to raise and lower the dock leveler 10-12 times. This operation will disperse the lubricants to the bearing surfaces and reduce friction. This procedure should be performed when the dock is not used for an extended period of time.

NOTE: DAMAGE TO THE DOCK LEVELER AND LIP WILL OCCUR IF THE LIP IS LEFT IN THE EXTENDED POSITION WHEN A TRUCK BACKS INTO THE DOCK.

OPERATING INSTRUCTIONS

CAUTION

Never operate the dock leveler when someone is in front of the lip.

Always restrain the truck/trailer being loaded/unloaded, i.e. by use of wheel chocks or a truck restraint device.

1. Raise the dock leveler by gently pulling the release chain at rear of the deck. (Hold the chain up until the dock rises to its highest position.) The lip will extend and lock automatically. (FIGURE #1)
2. To lower the dock into its work position, walk to lip end of the dock. The weight of the operator will lower the dock onto the truck or trailer. (FIGURE #2)
3. As soon as the lip is on the truck the dock is ready to be used to load or unload truck or trailer.
4. While in use the dock will raise and lower with the movement of the vehicle and the trailer.
5. When the truck/trailer departs the lip will fall to vertical and the dock may be walked down to the cross traffic stored position with lip behind the night lock.
6. If necessary, raise the dock 6" above dock using the release chain, to allow the lip to fall behind the night lock, and then walk the dock down to the cross traffic stored position with lip behind the night lock.

WARNING: DAMAGE TO THE DOCK LEVELER AND LIP WILL OCCUR IF THE LIP IS LEFT IN THE EXTENDED POSITION WHEN A TRUCK BACKS INTO THE DOCK.

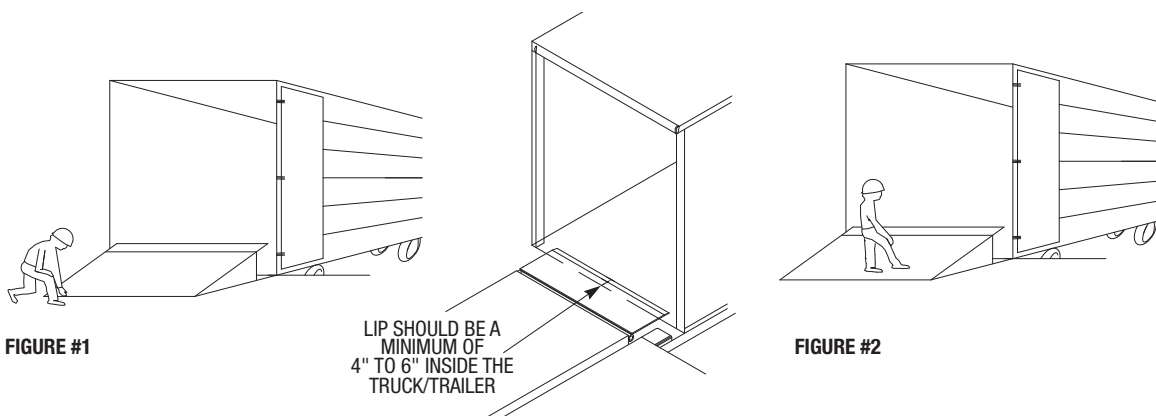

**PARTS LIST FOR
MECHANICAL DOCK LEVELERS**

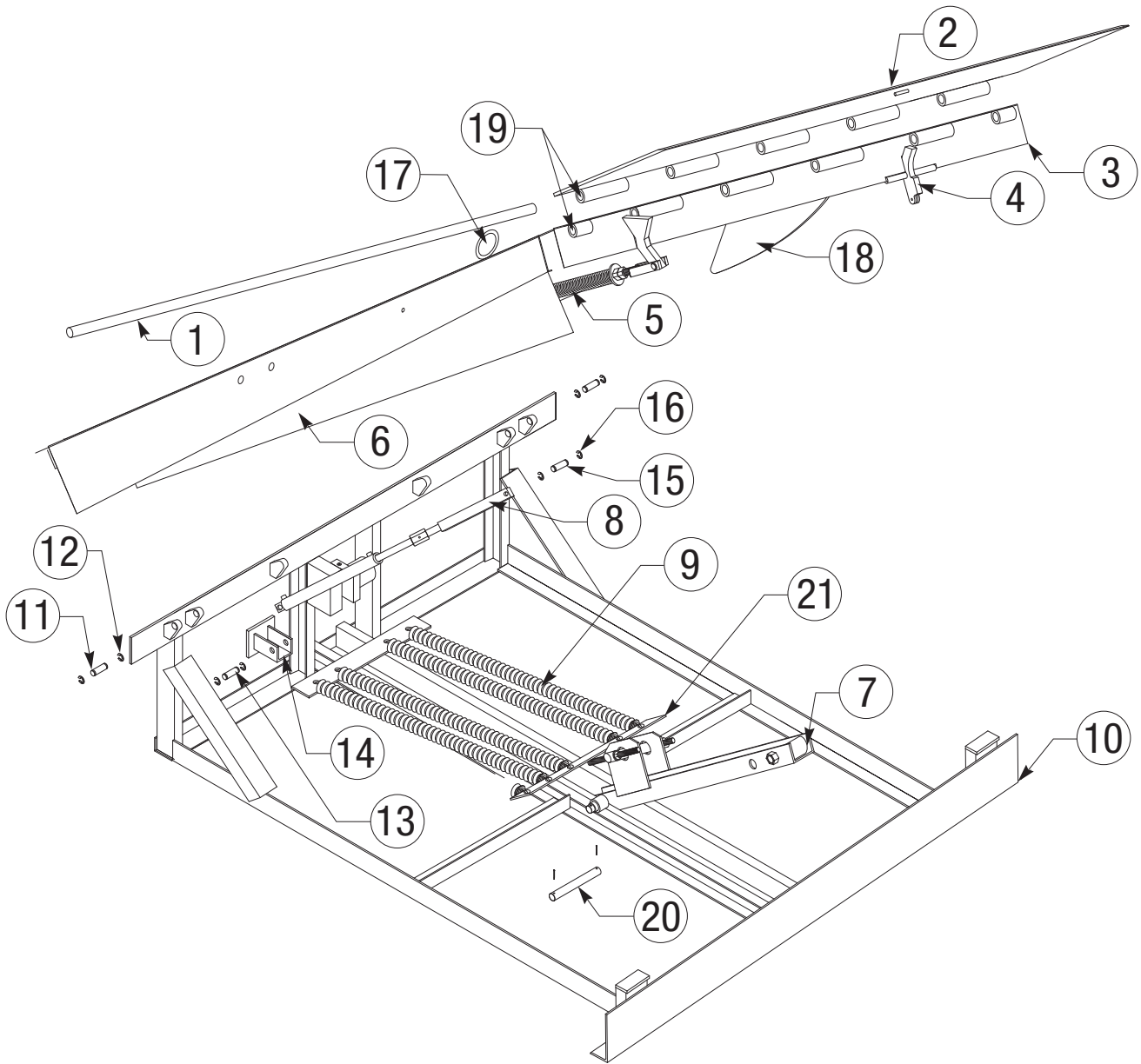

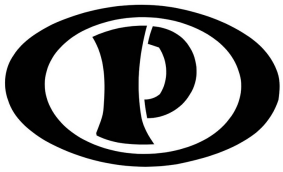

Perma Tech Inc.

PARTS LIST FOR MECHANICAL DOCK LEVELERS

Item #	Part #	Description
1	5P-MD 001-6, 001-7	Hinge Lip Pin
2	5P-MD 002-6, 002-7	Lip
3	5P-MD 003-6, 003-7	Top Deck Assembly
4	5P-MD 4	Lip Latch
5	5P-MD 5	Lip Assist Assembly
6	5P-MD 006-6,006-8,006-10	Telescopic Toe Guard
7	5P-MD 7	Lifting Arm Assembly
8	5P-MD 8	Hold Down Assembly
9	5P-MD 009-6, 009-810	Main Spring (Quantity Varies)
10	5P-MD 010-6,010-8,010-10	Base Frame Assembly
11	5P-MD 011-6, 011-7	Rear Hinge Pin
12	5P-MD 012	Cotter Pin
13	5P-MD 013	Back Hold Down
14	5P-MD 014	Hold Down Bracket
15	5P-MD 015	Front Hold Down Pin
16	5P-MD 016	Cotter Pin
17	5P-MD 017	Release Ring
18	5P-MD 018	Cam
19	5P-MD 019	Lip Hinge
20	5P-MD 020	Lifting Arm Pin
21	5P-MD 021-6,021-8,021-10	Spring Adjustment Bar Assembly

PARTS LIST FOR LIFTING ARM

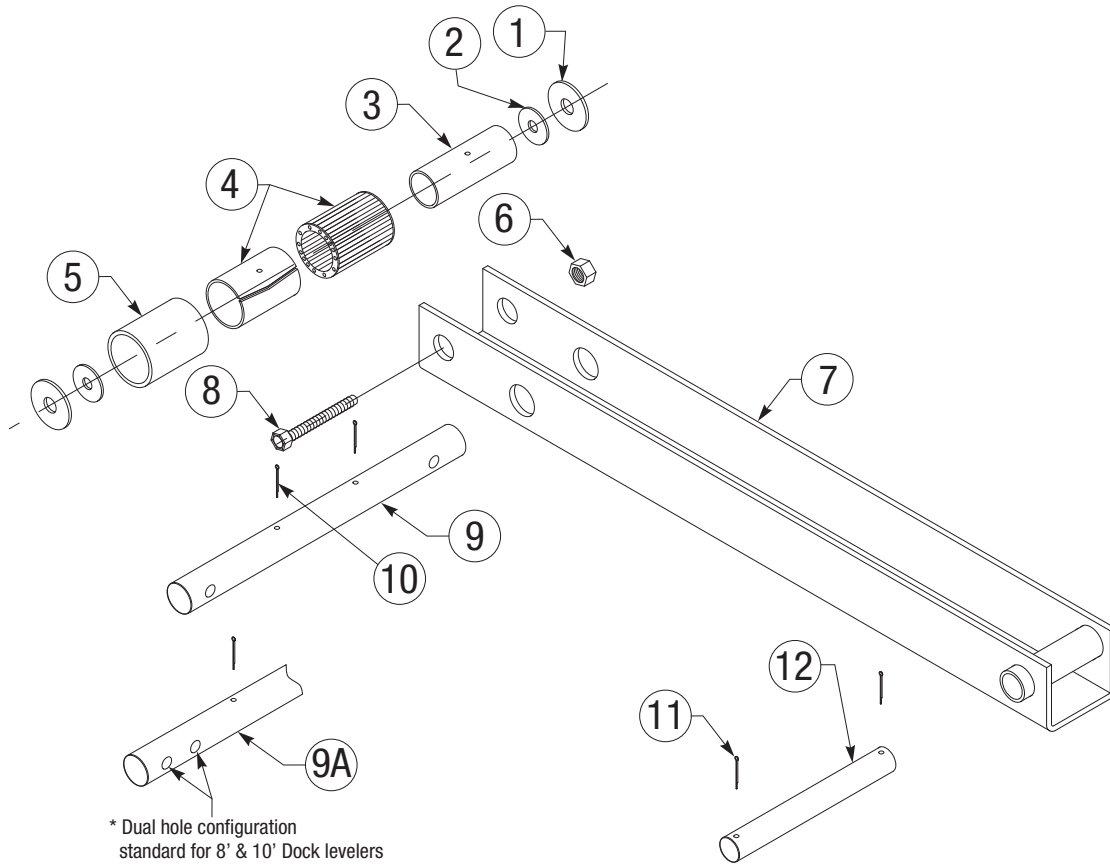

Item #	Part #	Description
1	5P-MD 022	Flat Washer
2	5P-MD 023	Washer Seal
3	5P-MD 024	Spacer Bushing
4	5P-MD 025	Roller Bearing
5	5P-MD 026	Roller
6	5P-MD 027	Nut
7	5P-MD 028	Lifting Arm
8	5P-MD 029	Bolt
9	5P-MD 030	Pull Pin (6' DOCK LEVELER)
9A	5P-MD 031	Pull Pin (8' & 10' DOCK LEVELER)
10	5P-MD 032	Cotter Pin 1/8" x 1 1/2"
11	5P-MD 033	Cotter Pin 1/8" x 1"
12	5P-MD 034	Lifting Arm Axle



Perma Tech Inc.

PARTS LIST FOR RATCHET HOLD DOWN

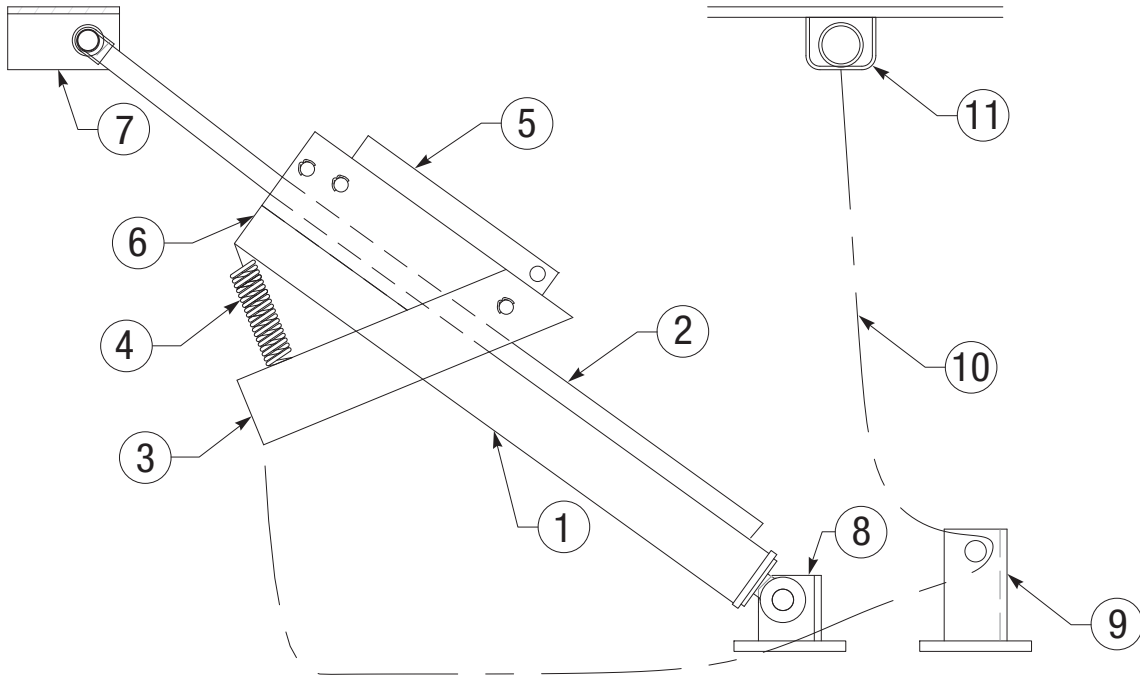

Item #	Part #	Description
1	5P-MD 037	Float Spring Housing
2	5P-MD 038	Ratchet Bar
3	5P-MD 039	Release Arm
4	5P-MD 040	Return Spring
5	5P-MD 041	Locking Bar
6	5P-MD 042	Ratchet Housing
7	5P-MD 043	Top Mounting Bracket
8	5P-MD 044	Bottom Mounting Bracket
9	5P-MD 045	Chain Guide Bracket
10	5P-MD 046	Release Chain c/w Pull Ring
11	5P-MD 047	Release Chain Holder

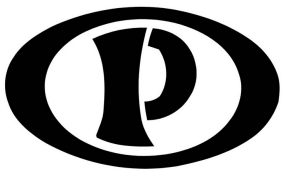

Perma Tech Inc.

PARTS LIST FOR LIP LATCH ASSEMBLY

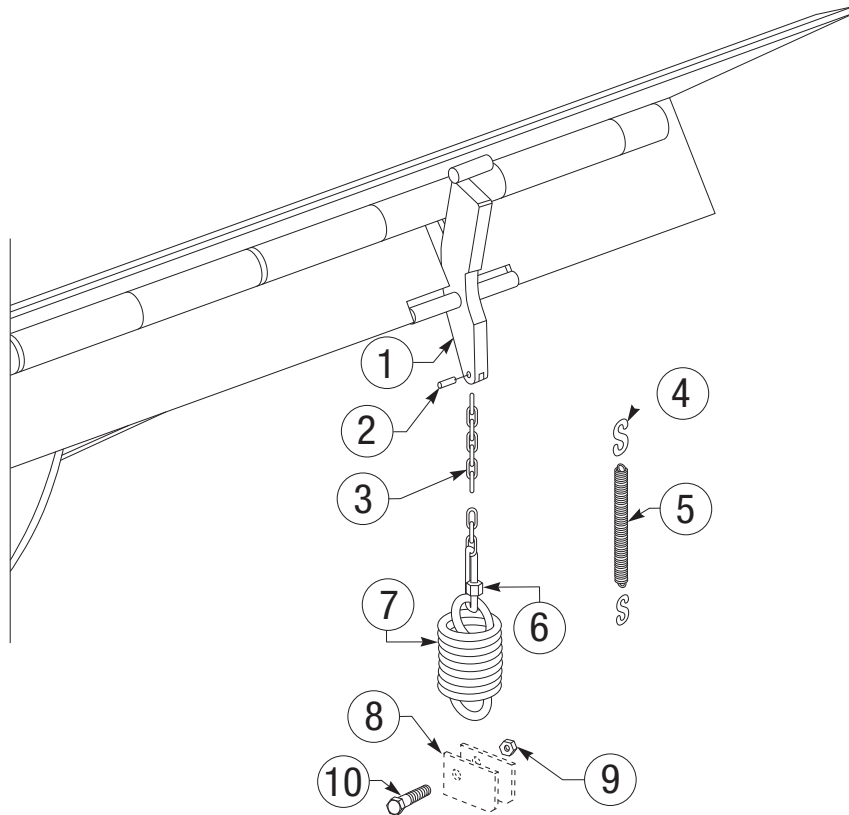

Item #	Part #	Description
1	5P-MD 054	Lip Latch
2	5P-MD 055	Roll Pin
3	5P-MD 056	Chain
4	5P-MD 057	S-Hook
5	5P-MD 058	Lip Stop Spring
6	5P-MD 059	Quick Link
7	5P-MD 060	Base Spring
8	5P-MD 061	Spring Bracket
9	5P-MD 062	Lock Nut
10	5P-MD 063	HHC Bolt



TROUBLE SHOOTING

NOTE

Prior to servicing the dock, always block up and barricade the ramp securely, and then enter the pit to clean or adjust.

PROBLEM	CORRECTIVE ACTION
1. Ramp fails to come up when release chain is	<ul style="list-style-type: none">- Check for proper lubrication of lifting and hold down assemblies.- Check for dirt and debris in the pit which may be hindering proper mechanical action.- Check for proper positioning of the board in the pit.- Check to make sure the hold down is not bent.- Check to be sure lifting arm is on the lifting cam and not binding on the side.
2. Lip fails to extend.	<ul style="list-style-type: none">- Check to see that operator is holding the release chain ring until ramp reaches its highest position.- Check for broken chain or chain joiner.- Check for lubrication of the lip hinge tubes.- Check for any binding of the board in the pit which may impede upward movement of the ramp.- Check the lip assist spring adjustment.- Check for proper lifting spring adjustments.
3. Lip extends but fails to lock.	<ul style="list-style-type: none">- Check the lip latch adjustment.<ul style="list-style-type: none">a) Spring may be disengaged.b) Spring may have no preload.c) Wire rope clip may be loose.- Check to see if the lip extends far enough to engage latch. See item "b" above.- Check for violence in the board caused by excessive lifting spring tension.- Check to make sure the lip latch is not broken off.- Check for excessive dirt in the lip hinge tubes.
4. If the lip fails to drop to it's vertical (pendant) position when the truck pulls away.	<ul style="list-style-type: none">- Check the lip latch assembly. Lubricate the latch and hinge tubes so that it moves freely.- Check lip hinge tube lubrication.



MAINTENANCE

NOTE: WITH PROPER CARE AND MAINTENANCE, YOUR MECHANICAL DOCK LEVELER WILL GIVE MANY YEARS OF TROUBLE FREE SERVICE.

LUBRICATION

Lubricate the following dock leveler parts every three months.
Use only the grease or oil specified for each part.

LIGHT OIL:

- a) Lip hinge tubes
- b) Lifting arm roller
- c) Lifting arm pivot
- d) Lip lifter & latch assembly
- e) Cylinder pivot points

GREASE:

- a) Main spring ends
- b) Rear hinge pins

MAIN COUNTER BALANCE SPRING ADJUSTMENT:

Adjust the counter balance spring.

To increase the upward ramp force, turn adjusting nuts clockwise.

To decrease the walk down force, turn adjusting nuts counter clockwise.

NOTE: ADJUST MAIN COUNTER BALANCE SPRINGS ONLY AFTER ALL OTHER FUNCTIONS ARE IN PROPER ADJUSTMENT.

WARRANTY

IMPORTANT

PLEASE READ CAREFULLY TO INSURE THAT YOU DO NOT VOID YOUR WARRANTY.

PERMA TECH DOCK LEVELERS – STANDARD WARRANTY

This warranty provides the owner with coverage for a one (1) year period based on normal eight (8) hour working day consisting of the following conditions:

- A) One year structural steel warranty for the base frame, main steel deck and steel hinged lip
- B) One year hydraulic warranty for power pack pump, main cylinder (ram & casing).
- C) One year (365 days) warranty for electrical components, electric motor and controls by respective manufactures, also complete lip-lifting mechanics, lip assist assembly, hinged lip tubing, main hinged lip bar, lip crown, main deck rear hinge lugs and pins, toe guards, hydraulic hose with fittings, hydraulic cylinder seals.

Perma Tech Dock Levelers has manufactured their equipment with the best of material and workmanship and should any defect develop or become evident during the guaranteed periods stated above, we shall repair or replace same upon notice and inspection by our authorized dealer.

WARRANTY CLAIRIFICATION:

- 1) Lip crown that has been decreased below the standard to meet the customer's requirement due to material handling equipment under clearance, which can effect the main hinged lip tubing, main hinged lip bar, front plate and capacity. The hinged lip crown established to satisfy the customer's requirements must be maintained but never exceed 80 degrees when open from the pendant position.
- 2) Weatherseals mounted on sides of unit or on curb, angles are susceptible to damage by various means which is not part of this warranty.
- 3) This warranty does not apply in respect to damage to any product or accessory or attachment thereof, caused by overloading or other misuse, neglect or accident, nor does this warranty apply to any product, or accessory or attachment thereof, which have been repaired or altered by other than the seller or it's authorized representative in any way, which in transit is not applicable to warranty as stated above.
- 4) This warranty will only be valid if the original supplier has received full payment for the equipment and services rendered and a preventive maintenance program established within ninety (90) days from date of installation.

WARRANTY RE: Longer operating hours

Customer's operating with a double shift up to sixteen (16) hours per day will reduce the complete warranty by half.

DISTRIBUTED BY:

Perma Tech Inc.

363 Hamburg Street | Buffalo, NY 14204

TF: 800.362.7325 | TEL: 716.854.0707

FAX: 716.854.0774

Email: Sales@PermaTechInc.com

www.PermaTechInc.com